



The Catalonia
Institute of Construction
Technology

Wellington 19
ES-08018 Barcelona
Tel. +34 93 309 34 04
qualprod@itec.cat
itec.cat



European Technical Assessment

ETA 18/0657
of 19.09.2018



General part

Technical Assessment Body issuing the ETA: ITeC

ITeC has been designated according to Article 29 of Regulation (EU) No 305/2011 and is member of EOTA (European Organisation for Technical Assessment).

Trade name of the construction product	1129, 1130s, 1030inox, 1131s and 1230s
Product family to which the construction product belongs	Multi-axis concealed hinge assemblies.
Manufacturer	CEAM AMADEO SPA Via Dante Alighieri 5 PO box n 39 IT-22072 Cermenate (Como) Italy
Manufacturing plant(s)	Via Dante Alighieri 5 PO box n 39 IT-22072 Cermenate (Como) Italy
This European Technical Assessment contains	15 pages including 3 annexes which form an integral part of this assessment.
This European Technical Assessment is issued in accordance with Regulation (EU) 305/2011, on the basis of	European Assessment Document 020001-01-0405.

General comments

Translations of this European Technical Assessment in other languages shall fully correspond to the original issued document.

Communication of this European Technical Assessment, including transmission by electronic means, shall be in full (excepted the confidential annex(es)).

Specific parts of the European Technical Assessment

1 Technical description of the product

1129, 1130s, 1030inox, 1131s and 1230s are multi-axis concealed hinge assemblies. The products consist of three parts: a door frame mounting body, a door mounting body and a connecting device linking the mounting bodies together in such a way as to allow the door to swing freely and to maintain the rotation axis of the leaf perpendicular to a horizontal plane during the full operational cycle. The connecting device provides a variable geometry within the multi-axis concealed hinge assemblies.

The different components of 1129, 1130s, 1131s and 1230s are mainly made of galvanised steel and zamac. 1030inox is made of stainless steel.

The products have been assessed with different coatings as follows:

- 1129: 1129 NIK, 1129 OTT, 1129 ARG.
- 1130s: 1130s BIA, 1130s NIK, 1130s BRS, 1130s NNE, 1130s OTT, 1130s ARG.
- 1131s: 1131s NIK, 1131s BRS, 1131s NNE, 1131s OTT, 1131s ARG.
- 1230s: 1230s BIA, 1230s NIK, 1230s NNE, 1230s OTT, 1230s ARG.

The multi-axis concealed hinge assemblies are described in Annex 1.

2 Specification of the intended use(s) in accordance with the applicable EAD

The invisible (concealed) hinges are intended for use on doors made of timber, metal or synthetic materials, allowing single and double swing door leaves to be mounted flush to its frame, forming a flush panel surface when the door is closed, and allowing the door to open to 180°.

The category of use of the hinges and the maximum door mass (each leaf, mass per 2 hinges) are given in the next table in accordance with EAD 020001-01-0405 and EN 1935¹.

Table 1: Intended of use of the hinges.

Product	Category of use		Door mass	
	Grade	Duty	Grade	Mass (kg)
1129	2	Medium	1	20
1130s	2	Medium	2	40
1030inox	2	Medium	2	40
1131s	3	Heavy	4	80
1230s	2	Medium	2	40

1131s is intended for use in fire resisting and/or smoke control doors and/or doors on escape routes (see table 5 and Annex 2).

¹ EN 1935. Building hardware. Single axis hinges. Requirements and test methods.

The provisions made in this ETA are based on a working life of the products of at least 10 years, provided that the conditions laid down in the manufacturer's instructions for the installation, use and maintenance are met. These provisions are based upon the current state of the art and the available knowledge and experience.

The indications given as to the working life cannot be interpreted as a guarantee given by the producer or Assessment Body, but are to be regarded only as a means for choosing the appropriate product(s) in relation to the expected economically reasonable working life of the works.

3 Performance of the product and reference to the methods used for its assessment

3.1 Performance of the product

The assessment of 1129, 1130s, 1030inox, 1131s and 1230s has been performed in accordance with EAD 020001-01-0405 *Multi-axis concealed hinge assemblies (March 2017)*.

Performance of the products is given in the next tables. Information is also shown in Annex 3 following the classification system established in EN 1935.

Table 2: Performance of 1129.

Product: 1129		Intended use: Multi-axis concealed hinge assembly	
Basic requirement	Essential characteristic	Performance	
BWR 2 Safety in case of fire	Reaction to fire	NPA ² (see 3.2.1)	
	Resistance to fire	NPA – Grade 0	
	Permanent function (durability)	200.000 cycles – Grade 7	
	Friction torque	≤ 2 N·m	
BWR 4 Safety and accessibility in use	Load deformation	40 kg Test door mass grade 1 (20 kg)	
	Overload	60 kg Test door mass grade 1 (20 kg)	
	Safety	Grade 1	
	Corrosion	1129 NIK	Not defined – Grade 0
		1129 OTT	Not defined – Grade 0
1129 ARG		High resistance – Grade 3	
Hinge grade		Grade 4	

² NPA: No Performance Assessed.

Table 3: Performance of 1130s.

Product: 1130s		Intended use: Multi-axis concealed hinge assembly	
Basic requirement	Essential characteristic	Performance	
BWR 2 Safety in case of fire	Reaction to fire	NPA (see 3.2.1)	
	Resistance to fire	NPA – Grade 0	
BWR 4 Safety and accessibility in use	Permanent function (durability)	200.000 cycles – Grade 7	
	Friction torque	≤ 2 N·m	
	Load deformation	80 kg Test door mass grade 2 (40 kg)	
	Overload	120 kg Test door mass grade 2 (40 kg)	
	Safety	Grade 1	
	Corrosion	1130s BIA	Mild resistance – Grade 1
		1130s NIK	Not defined – Grade 0
		1130s BRS	Not defined – Grade 0
		1130s NNE	Not defined – Grade 0
		1130s OTT	Not defined – Grade 0
1130s ARG		High resistance – Grade 3	
Hinge grade		Grade 7	

Table 4: Performance of 1030inox.

Product: 1030inox		Intended use: Multi-axis concealed hinge assembly
Basic requirement	Essential characteristic	Performance
BWR 2 Safety in case of fire	Reaction to fire	NPA (see 3.2.1)
	Resistance to fire	NPA – Grade 0
BWR 4 Safety and accessibility in use	Permanent function (durability)	200.000 cycles – Grade 7
	Friction torque	≤ 2 N·m
	Load deformation	80 kg Test door mass grade 2 (40 kg)
	Overload	120 kg Test door mass grade 2 (40 kg)
	Safety	Grade 1
	Corrosion	Very high resistance – Grade 4
	Hinge grade	

Table 5: Performance of 1131s.

Product: 1131s		Intended use: Multi-axis concealed hinge assembly	
Basic requirement	Essential characteristic	Performance	
BWR 2 Safety in case of fire	Reaction to fire	NPA (see 3.2.1)	
	Resistance to fire	Grade 1 (see Annex 2)	
BWR 4 Safety and accessibility in use	Permanent function (durability)	200.000 cycles – Grade 7	
	Friction torque	≤ 3 N·m	
	Load deformation	160 kg Test door mass grade 4 (80 kg)	
	Overload	240 kg Test door mass grade 4 (80 kg)	
	Safety	Grade 1	
	Corrosion	1131s NIK	Not defined – Grade 0
		1131s BRS	Not defined – Grade 0
		1131s NNE	Not defined – Grade 0
		1131s OTT	Not defined – Grade 0
		1131s ARG	High resistance – Grade 3
Hinge grade	Grade 11		

Table 6: Performance of 1230s.

Product: 1230s		Intended use: Multi-axis concealed hinge assembly	
Basic requirement	Essential characteristic	Performance	
BWR 2 Safety in case of fire	Reaction to fire	NPA (see 3.2.1)	
	Resistance to fire	NPA – Grade 0	
BWR 4 Safety and accessibility in use	Permanent function (durability)	200.000 cycles – Grade 7	
	Friction torque	≤ 2 N·m	
	Load deformation	80 kg Test door mass grade 2 (40 kg)	
	Overload	120 kg Test door mass grade 2 (40 kg)	
	Safety	Grade 1	
	Corrosion	1230s BIA	Mild resistance – Grade 1
		1230s NIK	Not defined – Grade 0
		1230s NNE	Not defined – Grade 0
		1230s OTT	Not defined – Grade 0
		1230s ARG	High resistance – Grade 3
Hinge grade	Grade 7		

3.2 Methods used for the assessment

3.2.1 Reaction to fire

Performance not assessed.

Characteristic not relevant for the hinges according to the existing harmonised technical specifications for doors.

3.2.2 Fire resistance

Fire resistance performance of 1131s assembled in a fire resistant door has been tested according to EN 1634-1³ and classified to EN 13501-2⁴.

Relevant information is given in Annex 2.

3.2.3 Permanent function (durability)

Permanent function (durability) has been tested in accordance with EN 1935 and section 2.2.3 of EAD 020001-01-0405.

3.2.4 Friction torque

Friction torque has been tested according to EN 1935 and assessed to EAD 020001-01-0405.

3.2.5 Load deformation

Load deformation has been tested according to EN 1935 and assessed to EAD 020001-01-0405.

3.2.6 Overload

Overload has been tested according to EN 1935 and assessed to EAD 020001-01-0405.

3.2.7 Safety

Safety has been classified according to clause 4.6 of EN 1935.

3.2.8 Corrosion resistance

The hinges have been tested according to EN 1670⁵ and section 2.2.5 of EAD 020001-01-0405.

³ EN 1634-1. Fire resistance and smoke control tests for door and shutter assemblies, openable windows and elements of building hardware. Part 1: Fire resistance test for door and shutter assemblies and openable windows.

⁴ EN 13501-2. Fire classification of construction products and building elements. Part 2: Classification using data from fire resistance tests, excluding ventilation services implemented.

⁵ EN 1670. Building hardware. Corrosion resistance. Requirements and test methods.

4 Assessment and verification of constancy of performance (AVCP) system applied, with reference to its legal base

According to the Decision 1999/93/EC of the European Commission, the system of AVCP (see EC Delegated Regulation (EU) No 568/2014 amending Annex V to Regulation (EU) 305/2011) given in the following table applies.

Table 7: AVCP System.

Product(s)	Intended use(s)	Level(s) or class(es)	System(s)
Building hardware related to doors and gates	Fire/smoke compartmentation and on escape route	Any	1

5 Technical details necessary for the implementation of the AVCP system, as foreseen in the applicable EAD

All the necessary technical details for the implementation of the AVCP system are laid down in the Control Plan deposited with the ITeC and agreed in accordance with EAD 020001-01-0405, section 3.

The Control Plan is a confidential part of the ETA and only handed over to the notified product certification body involved in the assessment and verification of constancy of performance.

The factory production control operated by the manufacturer shall be in accordance with the above mentioned Control Plan.

Issued in Barcelona on 19 September 2018
by the Catalonia Institute of Construction Technology.

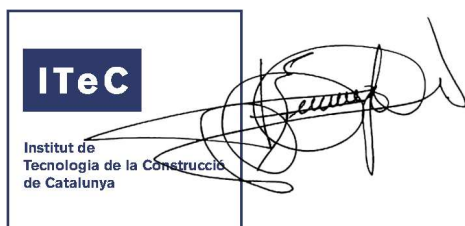

Ferran Bermejo Nualart
Technical Director, ITeC

ANNEX 1. Technical description of the hinges

A.1.1. 1129 overall drawing

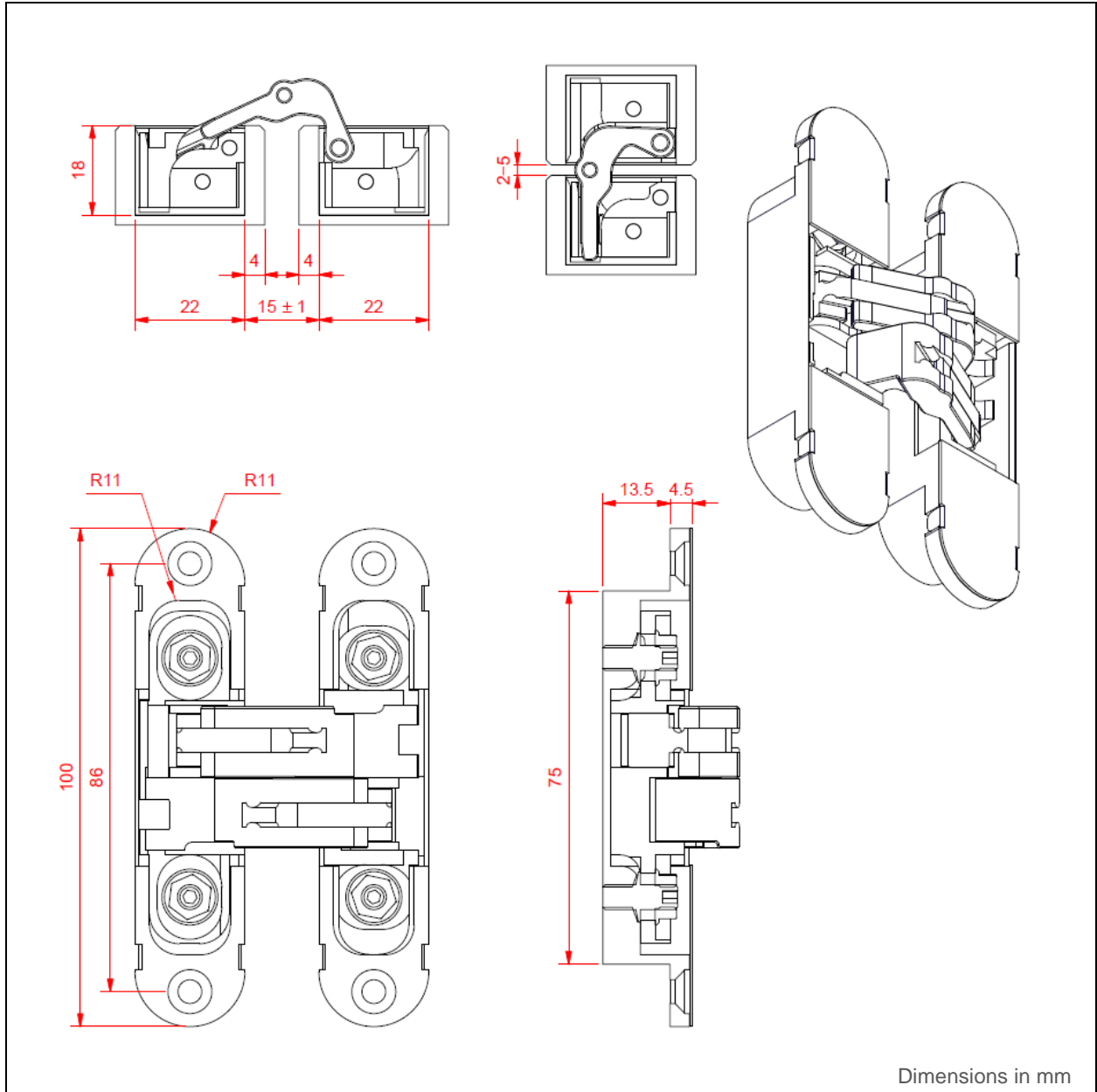

A.1.2. 1130s overall drawing

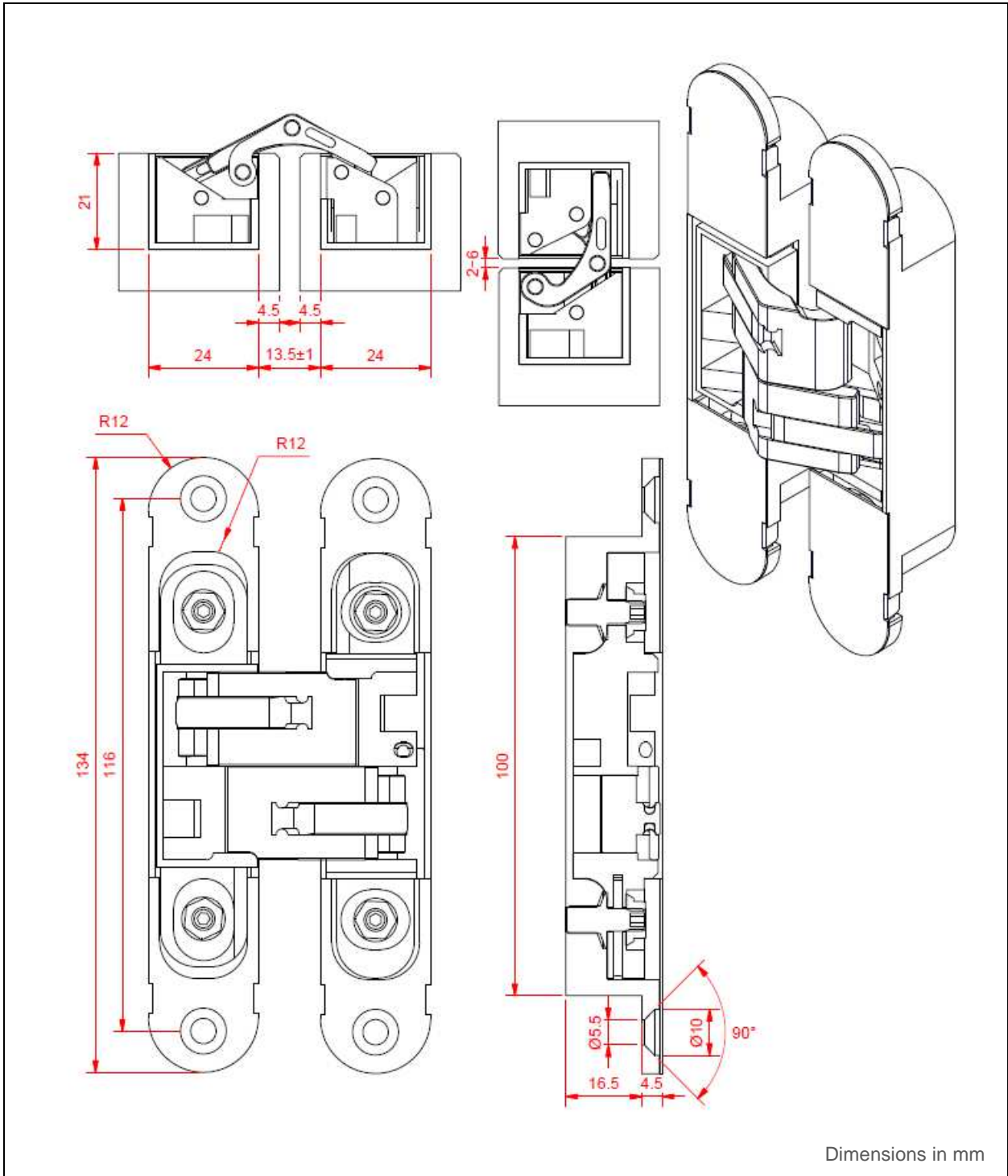

A.1.3. 1030inox overall drawing

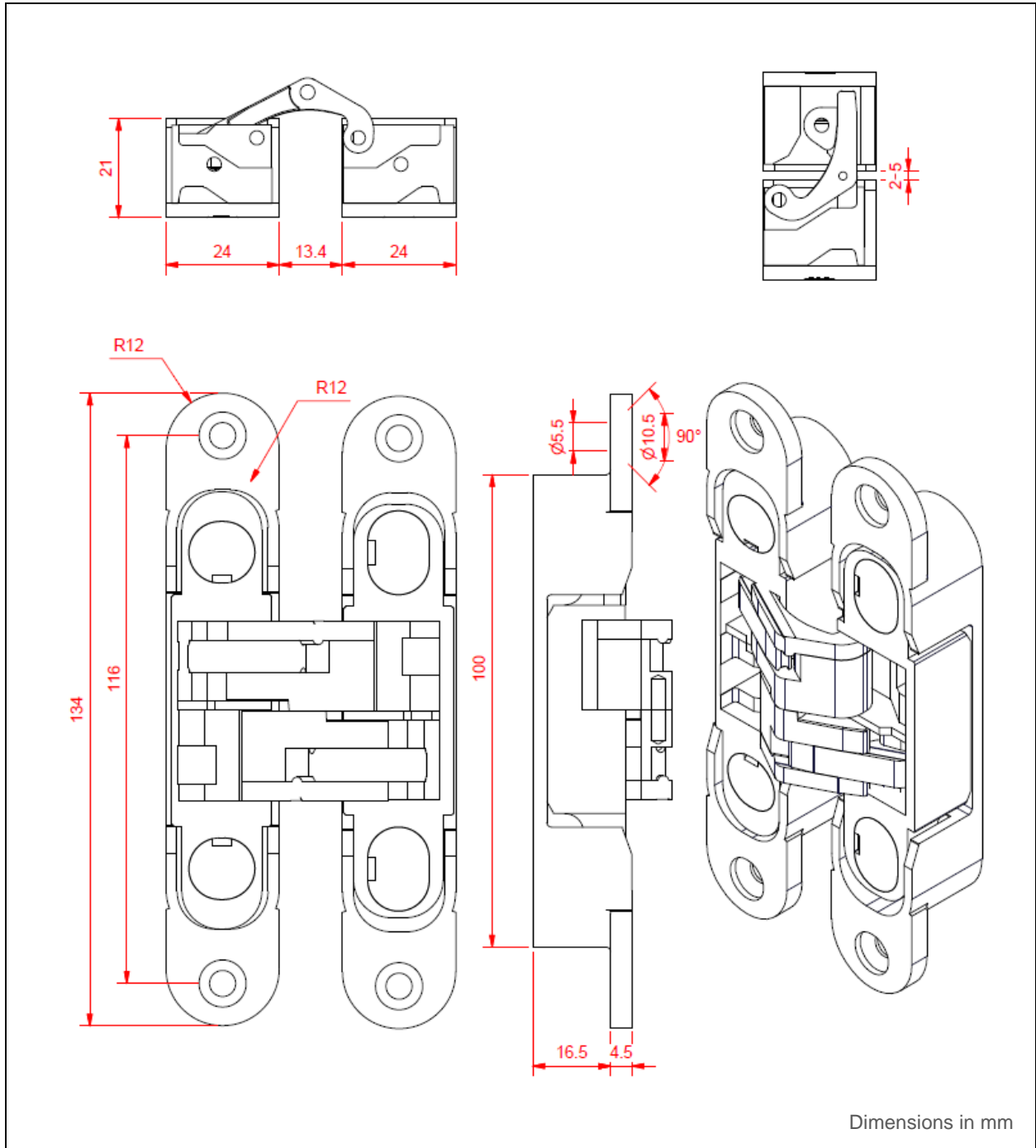

A.1.4. 1131s overall drawing

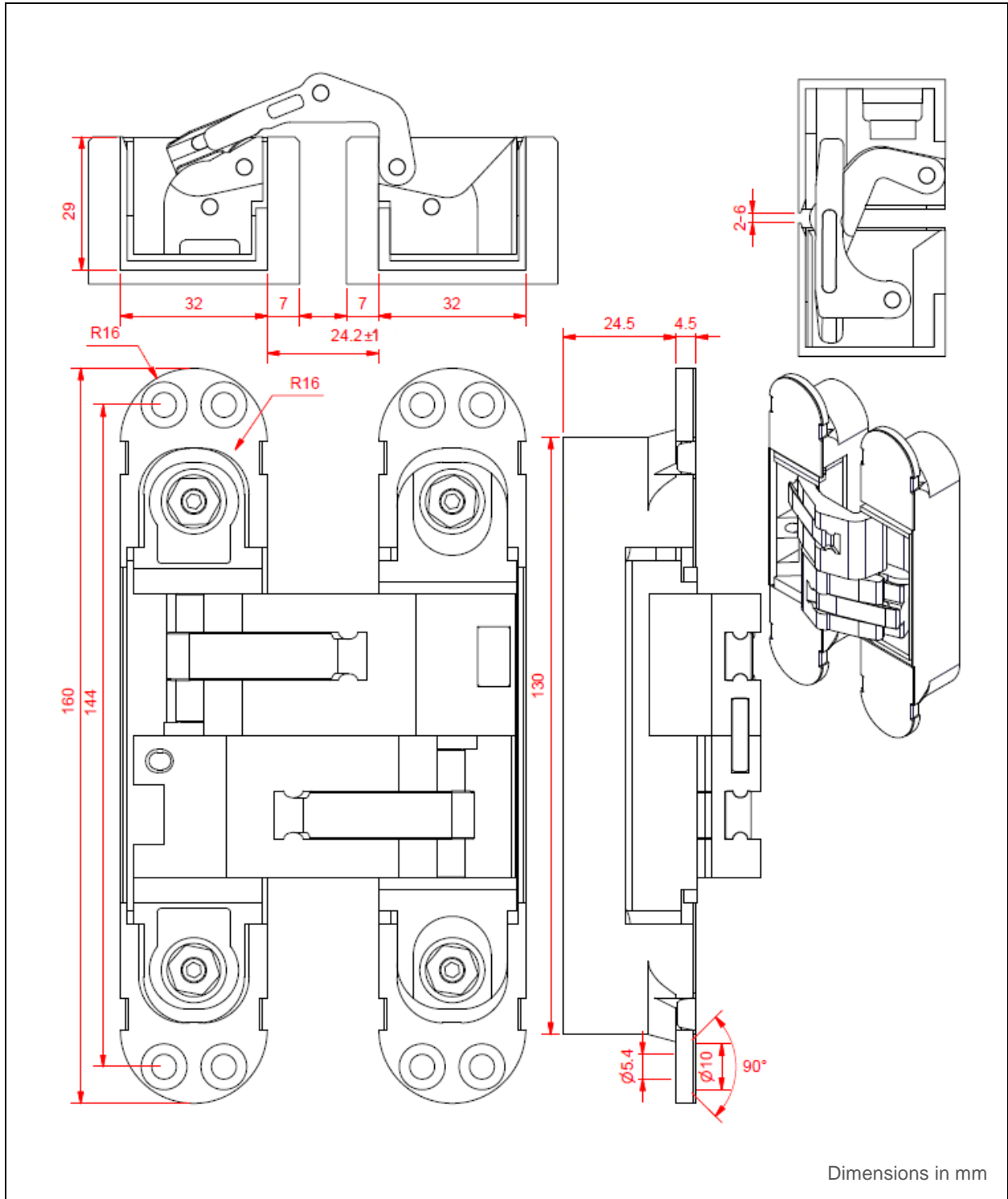

A.1.5. 1230s overall drawing

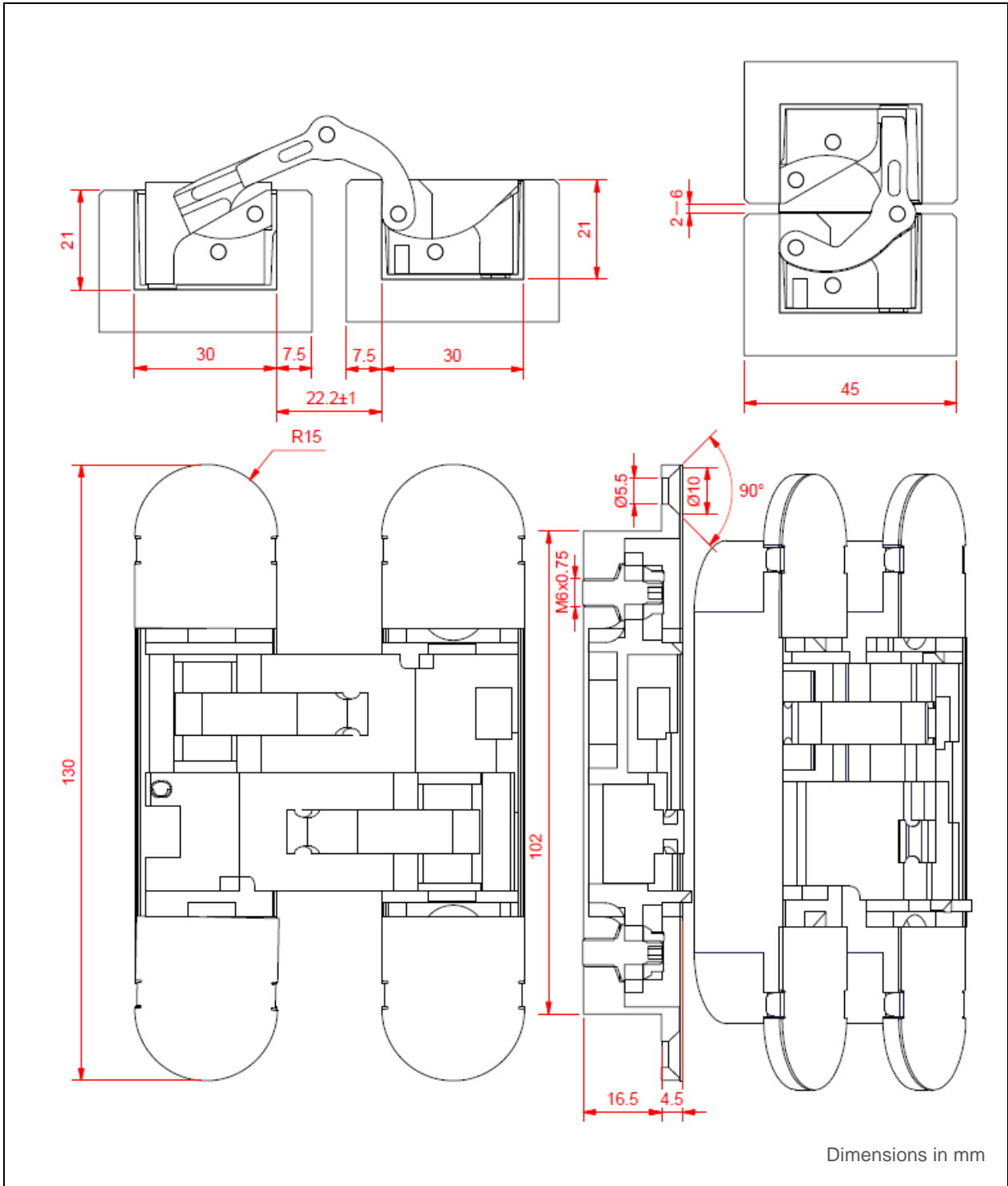

ANNEX 2. Resistance to fire performance of 1131s

Resistance to fire performance of 1131s has been assessed in accordance with EAD 020001-01-0405 and the product is classified as grade 1 in accordance with EN 1935.

1131s has been tested according to EN 1634-1 as a part of the fire resisting doors specified in this annex. For further details on the assembly tested, the performance and the results field of application, see relevant test and classification reports.

A.2.1. Fire resisting door “PC-EI-BO-55 mm 1 HOJA”

Table A.2.1: 1131s assembled in door “PC-EI-BO-55 mm 1 HOJA”.

Classification	EI ₁ 45 EI ₂ 45 (Door opening inwards the furnace)
Test & classification report	Applus 16/12320-934 Part 1 & 2
Door reference	PC-EI-BO-55 mm 1 HOJA
Door manufacturer	MARCOS MARTÍNEZ MINGUELA SA
Door general description (as tested)	Hinged timber single leaf door Overall dimensions (height x width x thickness): 2210 mm x 1125 mm x 55 mm Overall weight: 85,6 kg 3 x 1131s (centres at 305 mm, 1135 mm and 1965 mm from the bottom)

A.2.2. Fire resisting door “PC-EI-BO-55 mm 1 HOJA”

Table A.2.2: 1131s assembled in door “PC-EI-BO-55 mm 1 HOJA”.

Classification	EI ₁ 30 EI ₂ 30 (Door opening outwards the furnace)
Test & classification report	Applus 16/12622-1275 Part 1 & 2
Door reference	PC-EI-BO-55 mm 1 HOJA
Door manufacturer	MARCOS MARTÍNEZ MINGUELA SA
Door general description (as tested)	Hinged timber single leaf door Overall dimensions (height x width x thickness): 2190 mm x 1085 mm x 55 mm Overall weight: 80 kg 3 x 1131s (centres at 135 mm, 965 mm and 1795 mm from the bottom)

A.2.3. Fire resisting door “X397”

Table A.2.3: 1131s assembled in door “X397”.

Classification	EI ₁ 120 EI ₂ 120 (Door opening inwards the furnace)
Test & classification report	Applus 17/14097-794 Part 1 & 2
Door reference	X397
Door manufacturer	CEAM AMADEO SPA
Door general description (as tested)	Hinged timber single leaf door Overall dimensions (height x width x thickness): 2530 mm x 1130 mm x 120 mm Overall weight: 207 kg 5 x 1131s (centres at 290 mm, 990 mm, 1860 mm, 2075 mm and 2325 mm from the bottom)

ANNEX 3. Performance shown following EN 1935 classification system

Performance of the products, given in section 3.1, is also shown in the next tables according to the classification system established in EN 1935.

Table A3.1: Performance of 1129 following EN 1935 classification system.

1129 NIK	2	7	1	0	1	0	0	4
1129 OTT	2	7	1	0	1	0	0	4
1129 ARG	2	7	1	0	1	3	0	4

Table A3.2: Performance of 1130s following EN 1935 classification system.

1130s BIA	2	7	2	0	1	1	0	7
1130s NIK	2	7	2	0	1	0	0	7
1130s BRS	2	7	2	0	1	0	0	7
1130s NNE	2	7	2	0	1	0	0	7
1130s OTT	2	7	2	0	1	0	0	7
1130s ARG	2	7	2	0	1	3	0	7

Table A3.3: Performance of 1030inox following EN 1935 classification system.

1030inox	2	7	2	0	1	4	0	7
----------	---	---	---	---	---	---	---	---

Table A3.4: Performance of 1131s following EN 1935 classification system.

1131s NIK	3	7	4	1	1	0	0	11
1131s BRS	3	7	4	1	1	0	0	11
1131s NNE	3	7	4	1	1	0	0	11
1131s OTT	3	7	4	1	1	0	0	11
1131s ARG	3	7	4	1	1	3	0	11

Table A3.5: Performance of 1230s following EN 1935 classification system.

1230s BIA	2	7	2	0	1	1	0	7
1230s NIK	2	7	2	0	1	0	0	7
1230s NNE	2	7	2	0	1	0	0	7
1230s OTT	2	7	2	0	1	0	0	7
1230s ARG	2	7	2	0	1	3	0	7